

OPTIMIZING MANUFACTURING AND PRODUCTION PROCESSES

A Casebook of Successful Technology Development

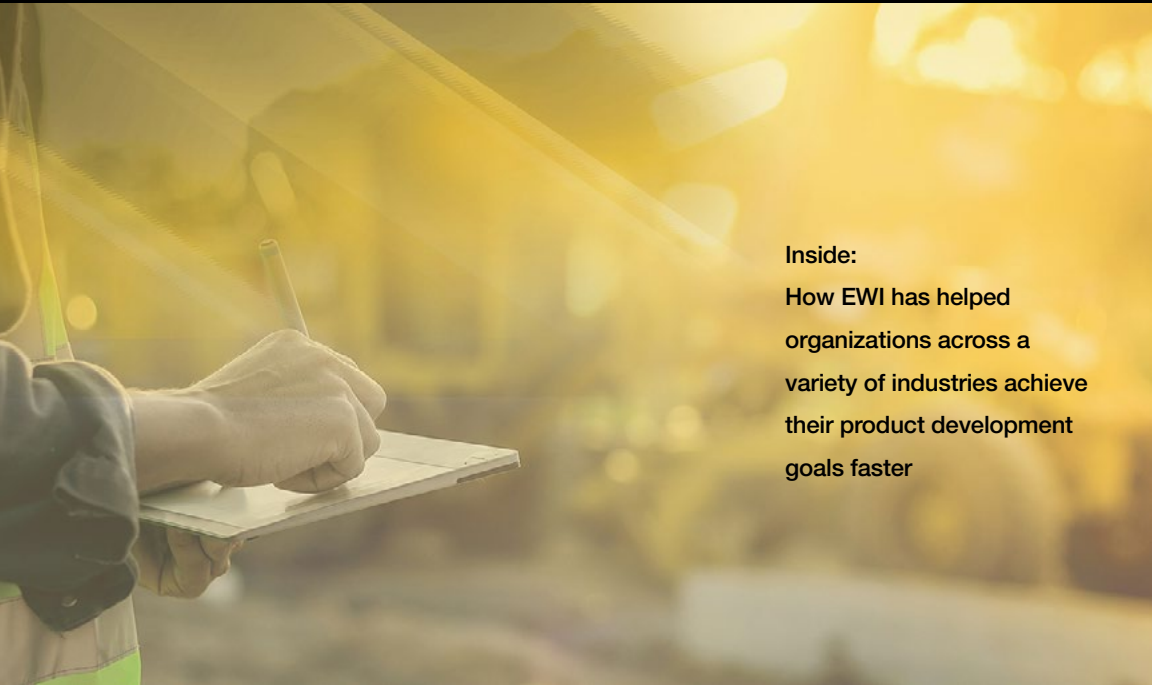

Inside:

How EWI has helped
organizations across a
variety of industries achieve
their product development
goals faster

EWI[®]
We Manufacture Innovation

Bringing a product to market is rarely straightforward. Without the right technology or process in place to support each stage of design, development and production, companies often face significant cost and efficiency challenges. Failing to thoroughly test materials and designs or optimize processes in the development stage increases the risk of falling short of industry certification standards and regulations, as well as time-to-market goals.

To stay competitive, today's manufacturers must adapt, innovate, and partner effectively.

EWI partners with organizations across a wide spectrum of industries, helping them optimize processes, technologies and materials, and speed time-to-market.

Companies turn to EWI to:

- Develop new processes and inspection techniques
- Determine better ways to join materials or very small components
- Select the best materials and methodologies to achieve efficiency and cost savings
- Improve line productivity, efficiency, and throughput
- Adjust or change processes to accommodate new material or product specifications
- Apply alternative technologies to optimize current processes

The case studies on the following pages highlight the impact EWI's industry-leading technology and expertise can have on an organization's competitive edge.

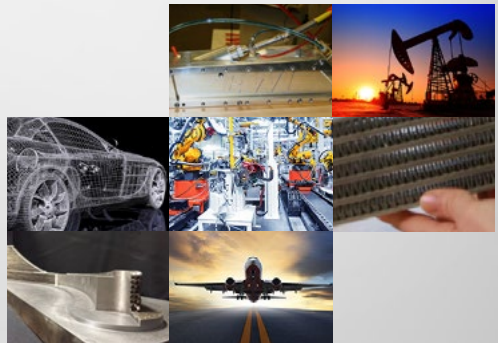
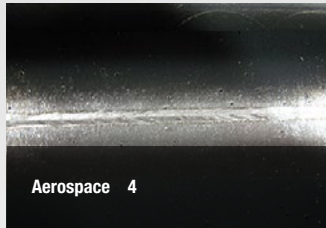
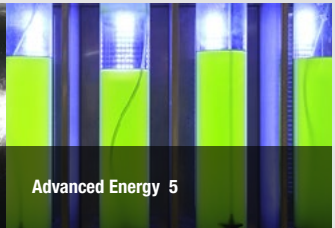

Table of Contents

Click on an industry to learn more about how these clients achieved the best outcomes with EWI support.



Aerospace 4



Advanced Energy 5

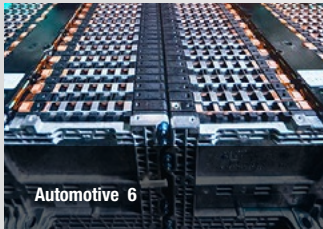

Automotive 6



Government/Defense 7



Heavy Manufacturing 8

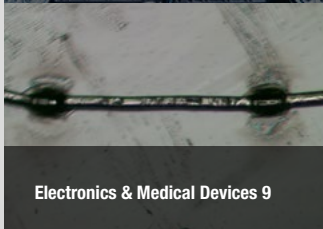

Electronics & Medical Devices 9



Oil & Gas 10

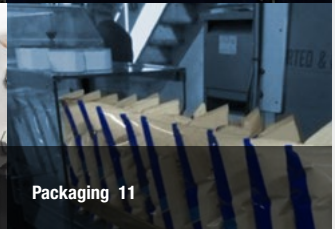

Packaging 11



Rail 12

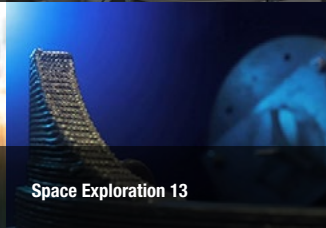

Space Exploration 13

EWI applies scientific methodology and a stage-gate development approach to inform quick innovation while minimizing risk and expense.

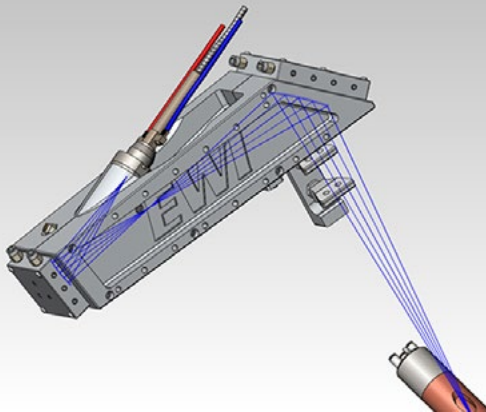

EWI will conduct in-depth iterative trials and feasibility studies to optimize your existing processes or develop new technologies to meet your objectives.

PROCESS FEASIBILITY STUDIES, IN-DEPTH ITERATIVE TRIALS

Aerospace

PROBLEM: EWI was approached with the unique challenge of producing 12-ft blanks of an expensive aerospace alloy for use in constructing components for an advanced vehicle. Due to weld quality requirements and material thickness, electron beam (EB) welding was the customer's preliminary choice; however, available systems could not accommodate parts of this size.

SOLUTION: To address this issue, EWI developed a laser welding solution, which presented an additional challenge, specifically the nearly two-minute long weld at power levels approaching 14 kilowatts. This long weld time resulted in substantial focal shift when using commercially available focusing optics. To combat this problem, EWI then invented (and subsequently patented) a new focusing optic solution, optimizing the process using a high-power fiber laser, and qualifying the welding procedure.

RESULT: Eleven blanks were laser welded successfully, qualified to AWS D17.1 Class A requirements, and shipped to the customer for subsequent processing for pre-production trials.

Aerospace

Advanced Energy

Automotive

Government/
Defense

Heavy
Manufacturing

Electronics &
Medical Devices

Oil & Gas

Packaging

Rail

Space Exploration

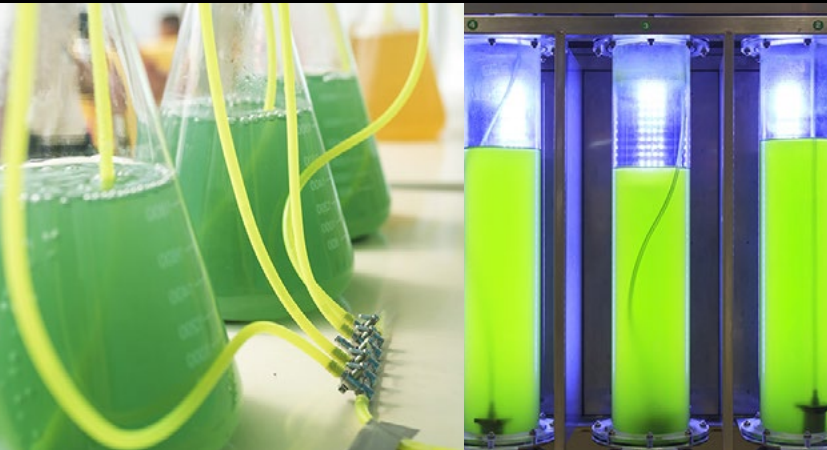

If a new solution is required, EWI's team of experts will investigate different materials, technologies, and methods to develop better options for your application.

PROCESS DEVELOPMENT & OPTIMIZATION

Advanced Energy

PROBLEM: A plastics packaging manufacturer that specializes in eco-friendly packaging solutions needed to design lab-scale equipment that could achieve and maintain the pressure necessary to extract oils from dried algae flakes. They hit a stumbling block due to the fact that the development unit's thermal gradients were causing unequal expansion and contraction that allowed pressure to bleed off.

SOLUTION: Knowing EWI's reputation for welding and design expertise, they commissioned the EWI team to re-design the device to maintain pressure integrity during high temperature differentials. The resulting device prototype—which EWI built and delivered to the client—not only maintained pressure, it included two new features. It was easy to open and close and included a drain valve for pulling off the oil at the end of the separation cycle.

RESULT: During subsequent trials, the new device has successfully and consistently extracted high clarity oil from the algae, demonstrating proof of concept. In addition, it provided improved ease of use, higher pressure quality, and improved safety, putting the company one step closer to providing a sustainable alternative to petroleum for fuel and plastics.

Aerospace

Advanced Energy

Automotive

Government/
Defense

Heavy
Manufacturing

Electronics &
Medical Devices

Oil & Gas

Packaging

Rail

Space Exploration

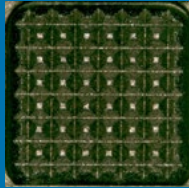
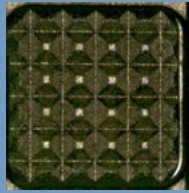

EWI does more than just identify a problem and name a solution; we work with you to develop, test, and validate new processes to make sure they work.

PROCESS DEVELOPMENT & OPTIMIZATION

Automotive

PROBLEM: A maker of lithium-ion battery systems was creating a powerful battery for a new line of electric/hybrid cars. The vehicle design changed several times during development, which necessitated modification of the battery packs. These spec alterations affected the interconnects in the battery modules and caused weld failure in several of the modules during shipping and assembly.

SOLUTION: EWI engineers conducted failure analysis testing to determine the cause of the inconsistent welds and retested the ultrasonic metal welding (UMW) method for validation. By devising and conducting a design of experiment (DOE), they were able to estimate the robustness of manufacturability for the battery packs, develop and document new welding processes, and design specialized tooling for the application.

RESULT: The successful outcome resulted in a reliable battery pack that enabled the development of a popular new line of electric cars offered by one of the world's top automobile corporations.

Aerospace

Advanced Energy

Automotive

Government/
Defense

Heavy
Manufacturing

Electronics &
Medical Devices

Oil & Gas

Packaging

Rail

Space Exploration



EWI engineers and specialists make full use of our state-of-the-art labs and resources to create new solutions for clients who are looking to innovate and improve their products.

PROCESS DEVELOPMENT & OPTIMIZATION

Government/Defense

PROBLEM: Existing commercial additive manufacturing (AM) machines operate in an “open loop” manner, with little or no real-time monitoring of the process to ensure quality requirements are consistently met. As a result, common defects can lead to degradation in part quality, potentially resulting in scrapped parts, parts that do not meet application requirements, and added costs.

SOLUTION: EWI was selected by America Makes, the National Additive Manufacturing Innovation Institute through funding provided by NIST to design, develop and build an open architecture AM test bed based on laser powder bed fusion (L-PBF) technology. The bed was outfitted with a variety of advanced sensors to enable the collection of critical in situ process data during the build.

RESULT: The EWI test bed allows for data-driven evaluation of the build, ensuring part quality and capability, and reducing scrap. This unique tool is now used to test a variety of in-process monitoring and inspection applications for additive manufacturing. EWI regularly publishes and shares these findings for the benefit of industrial AM users across all sectors.

Aerospace

Advanced Energy

Automotive

Government/
Defense

Heavy
Manufacturing

Electronics &
Medical Devices

Oil & Gas

Packaging

Rail

Space Exploration

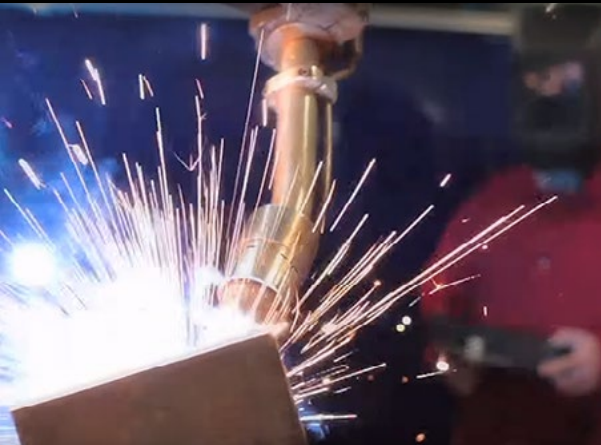

By approaching production challenges with a multidisciplinary perspective, EWI can offer elegant, comprehensive solutions to complex problems.

MATERIALS ENGINEERING, IN-DEPTH ITERATIVE TRIALS, PROCESS DEVELOPMENT & OPTIMIZATION

Heavy Manufacturing

PROBLEM: A heavy equipment frame manufacturer had incorporated robotic welding into production, but the welded joints needed significant manual welding afterwards to complete work in inaccessible areas. The company asked EWI to review the joint design, welding sequences, and tacking/fixturing techniques so it could maximize robotic welding and minimize manual wrap welding and rework.

SOLUTION: EWI worked onsite with the customer to conduct time studies during production runs, and identify process improvement opportunities. The team optimized aspects of the robotic welding, including weld sequencing, automated weld parameters, robotic-touch sensing techniques, and tandem GMAW welding techniques. In addition, they assessed and improved manual welding parameters and techniques, introduced best practices to the production staff, and provided specific recommendations to optimize weld designs, adjust required weld sizing, and eliminate welds through part consolidation.

RESULT: EWI's thorough review and process improvement efforts helped the company meet its goals for reducing overall welding time, reducing manual re-work, and improving automated welding productivity.

Aerospace

Advanced Energy

Automotive

Government/
Defense

Heavy
Manufacturing

Electronics &
Medical Devices

Oil & Gas

Packaging

Rail

Space Exploration

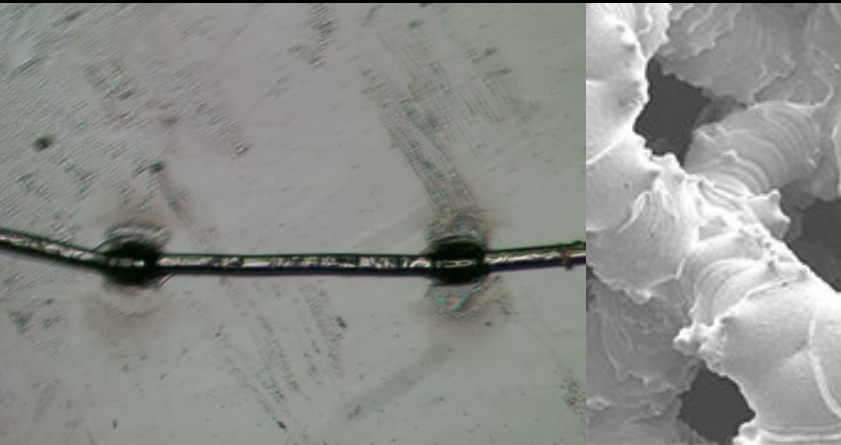

Working alongside you, EWI associates can develop out-of-the-box solutions that will give your product a competitive edge.

IN-DEPTH, ITERATIVE TRIALS, PROCESS DEVELOPMENT & OPTIMIZATION

Electronics & Medical Devices

PROBLEM: A medical device start-up approached EWI with the need to attach micro-sized titanium sensor pads to a small-diameter platinum wire for a neuro-modulation device.

SOLUTION: EWI developed a unique process that first involved using a vapor deposition chamber to deposit a 10- μm thin titanium film onto a sacrificial glass substrate. Next, a parallel gap micro-resistance welding system was used to weld a 75- μm platinum wire to the titanium thin film. The heat delivered to the titanium thin film during the weld process welds the platinum wire to the titanium and also delaminates the titanium film from the underlying sacrificial glass substrate, leaving only the small titanium pad attached to the wire in the ideal locations.

RESULT: Using both technical and process expertise, EWI developed an effective, affordable microjoining solution. The unique processes for welding the platinum to the titanium are essential to the ultimate success of the product.

Aerospace

Advanced Energy

Automotive

Government/
Defense

Heavy
Manufacturing

Electronics &
Medical Devices

Oil & Gas

Packaging

Rail

Space Exploration



As an independent technology and innovation service provider, EWI is able to provide unbiased, vendor-neutral, technology-agnostic guidance for solving your problem.

PROCESS DEVELOPMENT & OPTIMIZATION, MATERIALS ENGINEERING

Oil & Gas

PROBLEM: A manufacturer of piping assemblies for the oil and gas transmission market needed to improve the efficiency of its production process. Many of its assemblies required welding a flange to a formed part using a gas metal arc welding (GMAW) process. The company came to EWI seeking to drive down costs while maintaining superior quality.

SOLUTION: EWI identified friction welding as an alternative joining method to GMAW that could save time and material, adding up to greater efficiency. A weld test was designed using representative parts selected by the pipe producer. EWI developed and fabricated the tooling necessary for setting in an inertia friction welding machine. Twelve trials were conducted to develop welding parameters, during which EWI discovered geometric variations in the forged hole of the formed part. The part was corrected during the trials through cold forming and subsequent tests showed both the friction welding method and the EWI tooling were successful.

RESULT: To help the company move toward adoption, EWI provided next-step guidance including design modifications to the parts, material feasibility studies for other components produced by the company, and recommendations for production equipment and implementation.

Aerospace

Advanced Energy

Automotive

Government/
Defense

Heavy
Manufacturing

Electronics &
Medical Devices

Oil & Gas

Packaging

Rail

Space Exploration

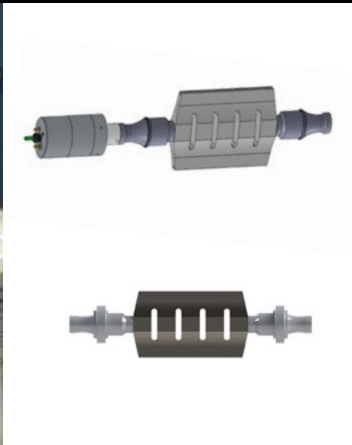
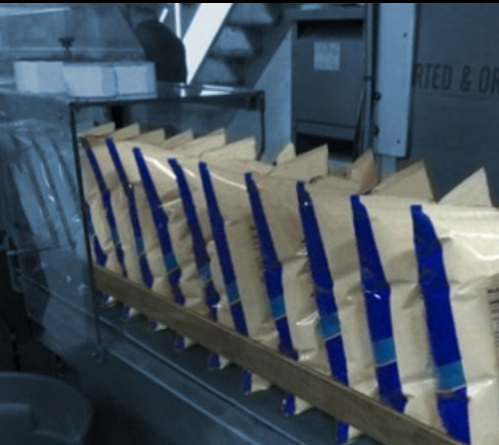

Over the last three decades, more than 40 of EWI's technology solutions have been patented and made available for use throughout the manufacturing industry.

IN-DEPTH ITERATIVE TRIALS PROCESS DEVELOPMENT & OPTIMIZATION

Packaging

PROBLEM: A processor and packager of food products needed a solution to help them minimize the amount of packaging material they were using in order to cut costs and improve environmental impact.

SOLUTION: EWI conducted feasibility studies to examine an innovative ultrasonic materials joining technology solution for the client's packaging applications and on its suitability for a full-scale process rollout. After developing and refining a unique process, EWI built and tested engineering prototypes to assist in commercial implementation on existing packaging lines, ultimately adapting the package sealing technology for use in high volume, high speed packaging equipment.

RESULT: The EWI solution enabled the client to surpass its waste reduction objectives, saving more than \$15 million in material costs, annually. The company estimates it will potentially achieve millions of dollars in annual savings due to the reduced product waste and energy consumption levels during packaging. In addition, the technology is patented as EWI GreenSeal™ and is now commercially available.

Aerospace

Advanced Energy

Automotive

Government/
Defense

Heavy
Manufacturing

Electronics &
Medical Devices

Oil & Gas

Packaging

Rail

Space Exploration



EWI can help you make your products safer, stronger, more durable, and more efficient.

IN-DEPTH ITERATIVE TRIALS, PROCESS DEVELOPMENT & OPTIMIZATION

Rail

PROBLEM: A Phase I project sponsored by the Federal Railroad Administration (FRA) needed to improve the safety and durability of repaired austenitic manganese frogs. The client approached EWI to develop an automated solution that would provide consistent, higher quality, “as new” repairs, in or out of track at increased productivity rate.

SOLUTION: EWI developed an automated flux cored arc welding (FCAW) frog repair process and delivered a repaired, frog to the Transportation Technology Center in Pueblo Colorado for testing.

RESULT: The performance of the repaired frog in the test track far exceeded expectations, accumulating over 118 million gross tons (MGT’s) prior to its scheduled removal and evaluation. Compared to baseline data, this represented a 240% increase in lifespan compared to frogs repaired using current shielded metal arc welding (SMAW) and FCAW processes, and more than a 100% increase in lifespan compared to a new, unrepaired frog. The success of this program led to an FRA-sponsored Phase II project with the goal of developing improved welding consumables, increasing overall productivity, and performing real-world testing in a heavy-haul line.

Aerospace

Advanced Energy

Automotive

Government/
Defense

Heavy
Manufacturing

Electronics &
Medical Devices

Oil & Gas

Packaging

Rail

Space Exploration

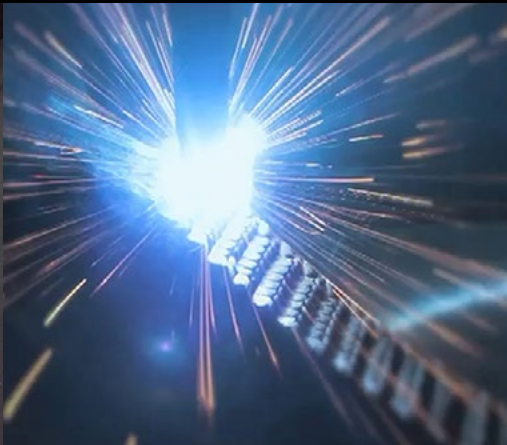

EWI solutions can make your business more successful in a competitive manufacturing marketplace.

PROCESS FEASIBILITY STUDIES & IN-DEPTH ITERATIVE TRIALS

Space Exploration

PROBLEM: A start-up business needed to develop a method to build space launch vehicle hardware on demand using additive manufacturing. The company needed support in demonstrating feasibility of the technology, developing the solution and deploying the process in their new factory.

SOLUTION: EWI developed and demonstrated a solution using wire fed large-scale direct energy deposition (DED). EWI also referred the company to a competent integrator to supply a sophisticated robotic solution to realize their needs.

RESULT: The company attracted Series B funding of \$35M based on the demonstrated hardware capability.

Aerospace

Advanced Energy

Automotive

Government/
Defense

Heavy
Manufacturing

Electronics &
Medical Devices

Oil & Gas

Packaging

Rail

Space Exploration



Armed with state-of-the-art technology and equipment, EWI engineers and technicians provide hands-on expertise through all phases of development. Informed by in-depth iterative trials, our detailed examinations cover materials, equipment, and processes, as well as form, fit and/or function considerations. We address each detail that could affect components—from customer expectations, to functionality, part fit-up, part-size variations, how to optimize based on material availability, and more.

Let us
help you:

- **Save** time
- **Save** money
- **Achieve** safety and sustainability goals
- **Increase** product durability
- **Speed** time to market
- **Reduce** the risk of setback during manufacturing rollout
- And more

To learn how EWI can help you identify, develop, and implement new production technologies and processes, contact Jon Jennings at

jjennings@ewi.org.

EWI[®]
We Manufacture Innovation

614.688.5152
ewi.org